

# *Electronic Christmas Tree Watering System*



By Mark McCuller 11/04  
Email [mcculler@mail.com](mailto:mcculler@mail.com)

# Table of Contents

I	Design Summery	Page 3
1.	Introduction	Page 4
	• Design Purpose	
	• Design Description	
2.	Technical Description	Page 5
	• Electronic Control System	
	• Sensors	
	• Schematics	
3.	Design Assembly	Page 9
	• Construction	
4.	Conclusion	Page 10
	• Safety Issues	
	• In Conclusion	

# Electronic Christmas Tree Watering System

## I DESIGN SUMMARY

The Electronic Christmas Tree Watering System is a device that will automatically water your Christmas tree when the water level goes low in the tree stand reservoir. A Christmas tree that is watered consistently will last longer and be fresher than a tree that is watered occasionally. A dry Christmas tree can be a fire hazard. With all the ornaments and presents around the Christmas tree it becomes a hassle when you have to bend down to see the water level and fill the Christmas tree stand with water. The Electronic Christmas Tree Watering System will automatically maintain a constant water level of so your tree will remain fresher and last longer during the Christmas holiday season. See Figure 1.

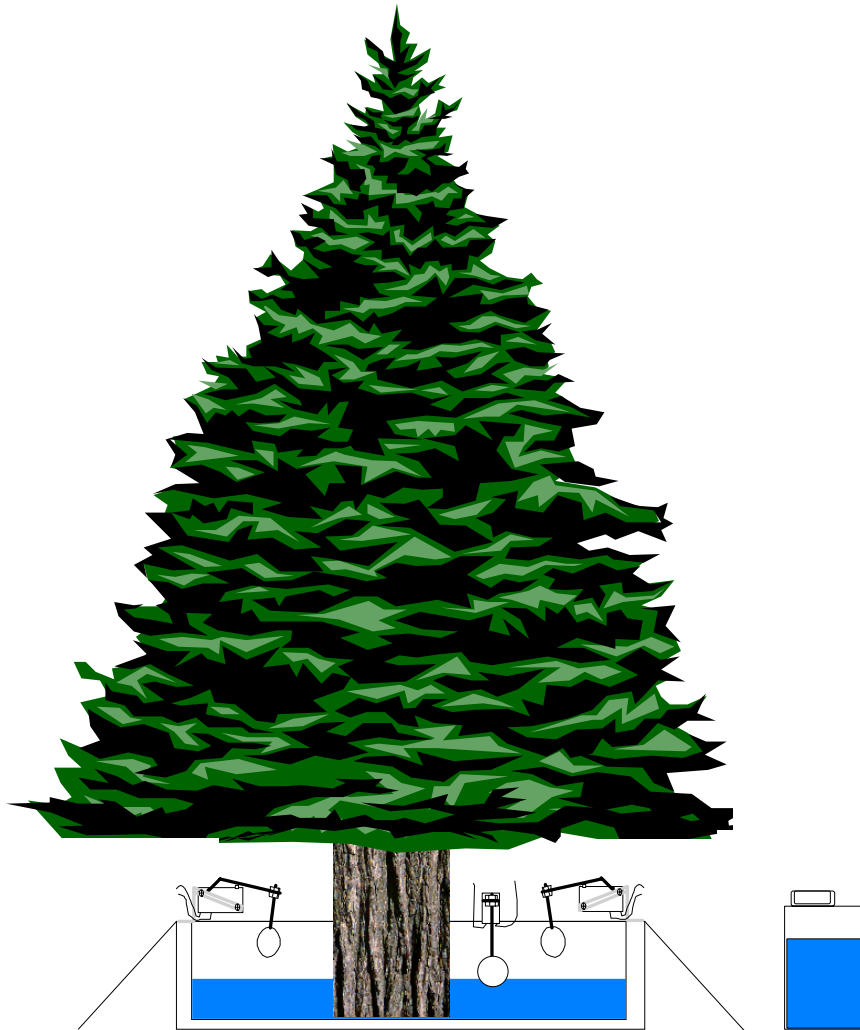

**Figure 1**  
Christmas Tree

# 1. INTRODUCTION

## DESIGN PURPOSE

The purpose of the Electronic Christmas Tree Watering System is to use water level sensors to sense the water level and fill up the reservoir of the Christmas tree stand automatically. It has two sensors for safety of water overflow and one for water level control. A dry Christmas tree can be fire hazard. With the Electronic Christmas Tree Watering System will automatically maintaining a constant level of water for the Christmas tree so you don't have to worry about it anymore.

## DESIGN DESCRIPTION

The purpose of the Electronic Christmas Tree Watering System is to use water level sensors to sense the water level and fill up the reservoir of the Christmas tree stand automatically when required. The Electronic Christmas Tree Watering System consists of five parts listed below. See Figure 2.

- Water Level Sensors
- Water Reservoir
- Water Pump
- Logic Control System
- Power Supply

The water level sensors will maintain the water level and provide overflow control. It has two sensors for safety for water overflow control and one for water level control. The plastic 1-gallon Rubbermaid container will be the reservoir to water the tree. The water pump is standard automotive windshield washer pump that works on 12VDC. The logic control system will provide the control for safely watering the tree. The power supply powers the water pump (12VDC) and the control system (5VDC) circuit.

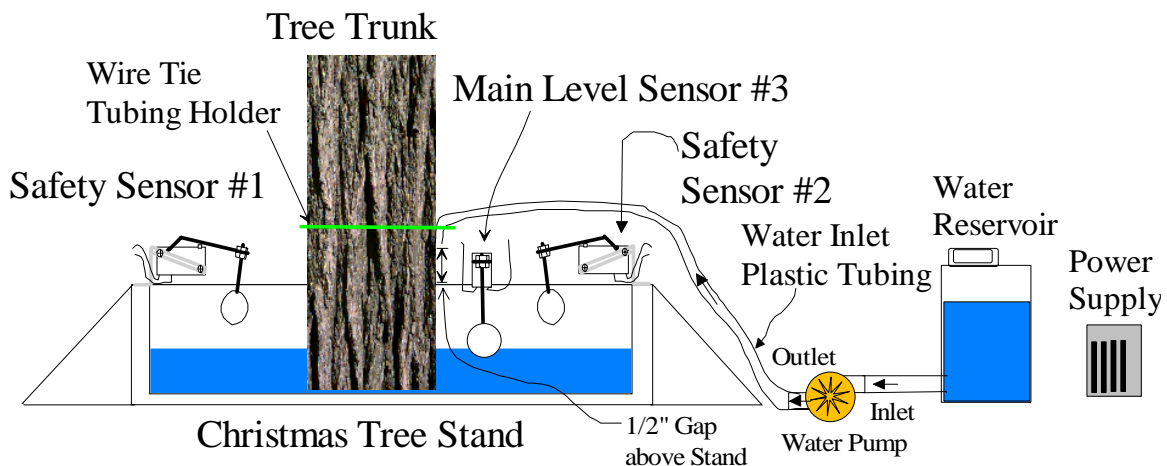

**Figure 2**

Electronic Christmas Tree Watering System

## 2. TECHNICAL DESCRIPTION

### ELECTRONIC CONTROL SYSTEM

The Electronic Christmas Tree Watering System is a digital control circuit for logic control using AND Gates. In Digital electronics Logic High=1 (True) and Logic Low =0 (False) the truth table of the AND Gate is shown below in Figure 3.

AND TRUTH TABLE		
INPUT A	INPUT B	OUTPUT
0	0	0
0	1	0
1	0	0
1	1	1

**Figure 3**  
AND Gate

Level Sensor Truth Table				
Sensor Safety Switch #1	Sensor Safety Switch #2	Sensor Level Switch #3	Water Pump Motor	Motor Status
0	0	0	0	OFF
0	0	1	0	OFF
0	1	0	0	OFF
0	1	1	0	OFF
1	0	0	0	OFF
1	0	1	0	OFF
1	1	0	0	OFF
1	1	1	1	ON

**Figure 4**  
Sensor Logic Table

The Truth Table for all sensor switch positions is shown in Figure 4. The only condition that turns on the water pump is a Logic 1 (High) from each sensor switch. This is shown on the last line of the chart above (Figure 4) with all 1's and motor status is ON. All other logic positions will turn off or prevent the water pump from working. This will provide a layer of safety to prevent an overflow of water going out of the Christmas tree stand.

### SENSORS

The two safety sensor switches #1 and #2 function as a safety system to turn off the water pump and prevent water from overflowing the tree stand and spilling water on the floor. See Figure 5. The safety switches are positioned with Styrofoam floats hanging down and not making contact with the water. When the water lifts these sensors #1 and #2 it will open the contact and stop the water pump. The sensor safety switch #1 turns on/off the 12VDC going to the relay for the pump power. The sensor safety switch #2 is connected to the digital control circuit AND Gate Pin1 as shown in Figure 9. The safety sensor switches #1 and #2 need to be setup to open the contact switch when the water level has reached the ½” mark on the lip of the Christmas tree stand. The sensor level switch #3 is the main sensor switch that floats on the water level to turn the water pump on and off. When the sensor level switch #3 is in the up position the pump is turned off and in the

down position the pump is turned on. Sensor switch #3 is setup to stop the water pump when the water level is  $\frac{3}{4}$ " from the top lip of the Christmas tree stand. For greater detail the Sensor level switches is shown in Figure 5, 6, and 7.

### Main Level Sensor #3

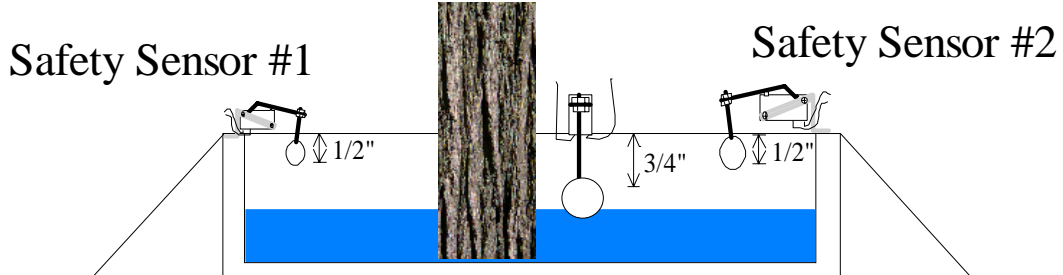

**Figure 5**  
Level Sensor Positions

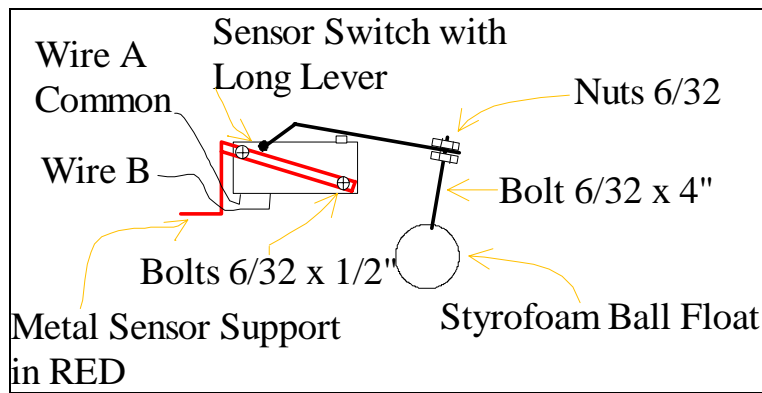

**Figure 6**  
Water Level Sensor

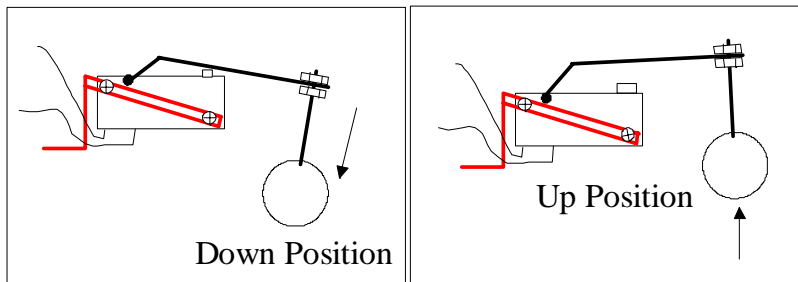

**Figure 7**  
On-Off Switch Positions

## SCHEMATICS

The schematic for the control system is listed below in Figure 9. The circuit works as follows; When the Sensor safety switch #1 is not in contact with the water it will power the 12VDC going to the relay. When sensor safety switch #2 is not in contact with the water it will send a High (Logic 1, 5VDC) to the AND Gate Pin1. The output of the AND Gate (Pin3) will send a logic High (1) to the common terminal of water level switch#3. When the water level is good (Full) it will send a logic zero (Logic 0, 0V) to Pin4 and the output of the last AND Gate (Pin6) will give a logic Zero (0, 0V) output. The AND Gate output will not bias the transistor 2N2222 so the relay will be in the open position so the water pump has no power. When the water level at switch#3 is low it will send logic High (Logic 1, 5V) to Pin4 that will make the AND Gates output a Logic High (Pin6) to the base of the transistor 2N2222 and this will bias the transistor and turn on the relay and will power the water pump. The pump will turn off again when water level switch #3 rises to the full position. The schematic shown in Figure 10 is a Non-Digital simple circuit that does the same as the digital circuit. The Allied Electronics parts list is shown in Figure 8.

Amount	Parts Description	Allied Part #
1	Quad 2 input AND GATE MC74HC08	568-3237
1	1N4148 Diode	263-1538
1	Relay DK1A-5V	788-0085
1	2N2222 Transistors NPN	248-1004
1	Resistors 1K Ohm 1/2W Carbon Film	832-9016
1	ProtoBoard 0.1"x0.1" Spacing	237-0119
1	Power Supply +12VDC and +5VDC	800-8071
3	Level Sensor Switch	908-1180
1	Dip Socket 14Pin	512-4681
8	Terminal Block PCB Mount	607-7155
	<b>Additional Parts Below</b>	
1	Automotive Windshield Water Pump	
1	Plastic 1-Gal Reservoir	
1	Plastic Tubing 12 Ft	
6	Bolts and Nuts 6/32 x 1/2"	
3	Bolts and Nuts 6/32 x 4"	
3	Metal Support for Sensors	
3	Styrofoam Float (1 1/2" Balls)	
1	Cable 18-2 Stranded Sensor Wire 15ft	
1	Cable 18-2 Stranded Power Wire 10ft	

**Figure 8**  
Parts List

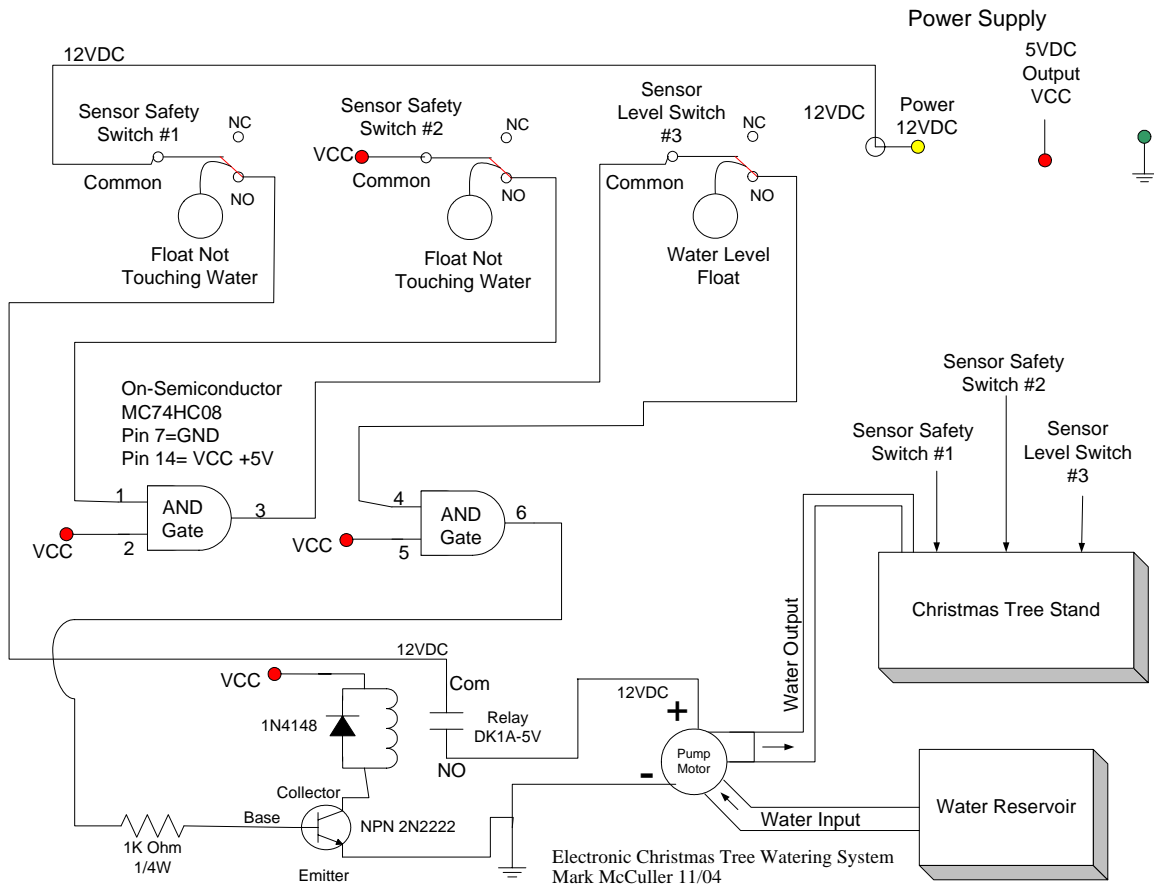

**Figure 9**  
Schematic of Watering System

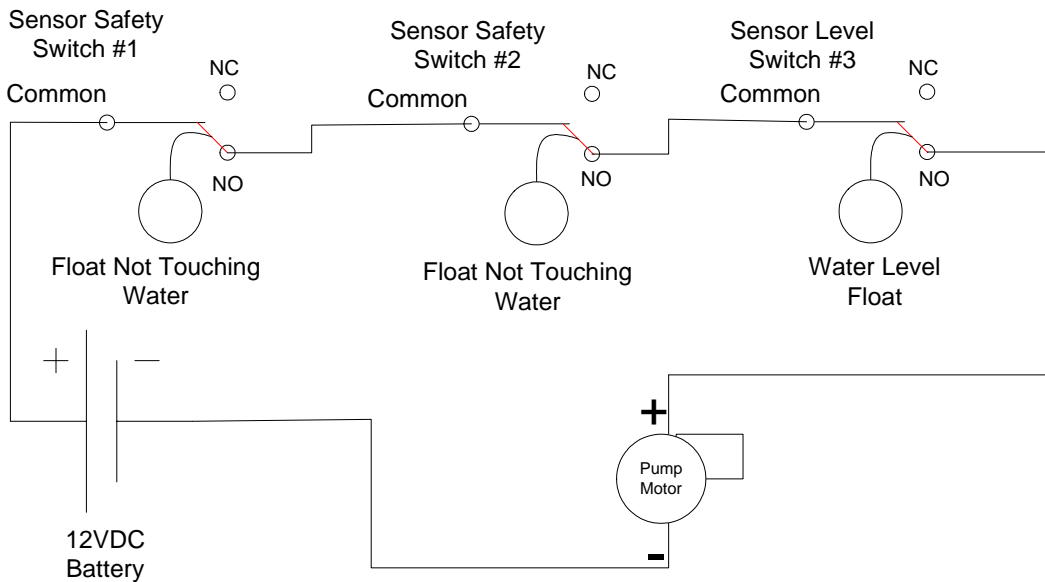

**Figure 10**  
Circuit Diagram Non-Digital

### 3. DESIGN ASSEMBLY

#### CONSTRUCTION

The Electronic Christmas Tree Watering System works best with a large opening in the reservoir for making water refilling easier. The plastic tubing is ¼” ID that is glued and sealed in the water reservoir container and connected to the water inlet of the water pump motor. Note different window washer pumps have different sizes on inlet and outlets. The plastic tubing from the output of the water pump is supported ½” (Gap) above the rim of the tree stand to prevent siphoning as shown in Figure 2. Solder in all components listed on the schematic (Figure 9) the layout is shown below in Figure 11. Solder in the terminal block for power, sensor, and pump motor connections. Wire up sensors, water pump, and power. Test all three sensors for water pump operations and safety stops. Test to make sure that there is no water leaks at all.

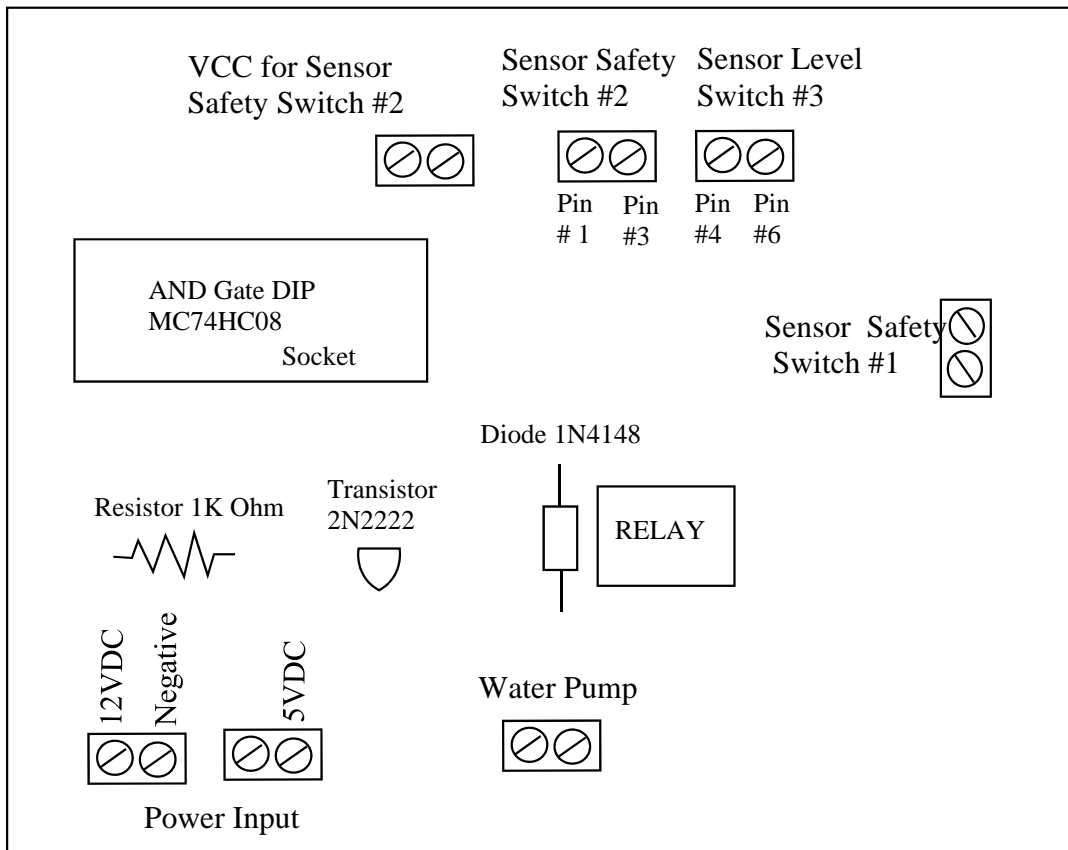

Figure 11  
Component Layout

## 4. CONCLUSION

### SAFETY ISSUES

When working around water and electricity use caution and adhere to all National Electrical Codes (NEC) and local and state electrical codes to prevent electrical shock and fire. It is your responsibility, so play it safe. The AC to DC power supply should be on a GFI circuit. You can also power the Electronic Christmas Tree Watering System from battery power to make it safer.

### In CONCLUSION

The Electronic Christmas Tree Watering System is a device that is so simple but works so good and will be used for many years to come. I've had mine for over 15 years and it still works great. I hope you enjoy the Electronic Christmas Tree Watering System as I did making it. Send me an email [mcculler@mail.com](mailto:mcculler@mail.com) and let me know what you think of the idea. Enjoy... Have a Merry Christmas.

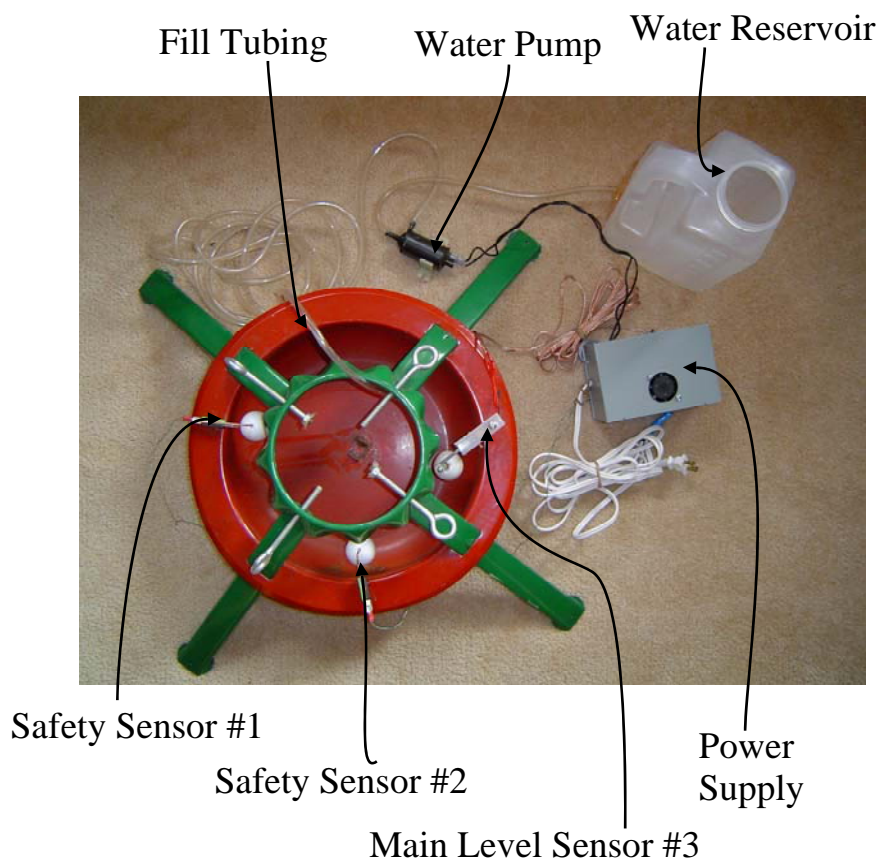

**The Electronic Christmas Tree Watering System**